

# Computational models of natural systems - I

Richard Clayton

Department of Computer Science

University of Sheffield



The  
University  
Of  
Sheffield.

# Who am I?

- BSc Applied Physics, University of Durham, 1986
- PhD Medical Physics, University of Newcastle upon Tyne, 1990
- British Heart Foundation Research Fellow, Freeman Hospital, Newcastle upon Tyne, 1991-1998
- British Heart Foundation Basic Science Lecturer, Physiology, University of Leeds, 1998-2002
- Academic in Computer Science, University of Sheffield, 2003 -



# Outline

“A scientific model is a simplified abstract view of complex reality. A scientific model represents empirical objects, phenomena, and physical processes in a logical way” – Wikipedia

Aim: introduce some tools for building models of function in natural (biological) systems

- Simple models of population dynamics;
- Steady state solutions;
- Oscillations;
- Numerical approximations

# Models of complex systems

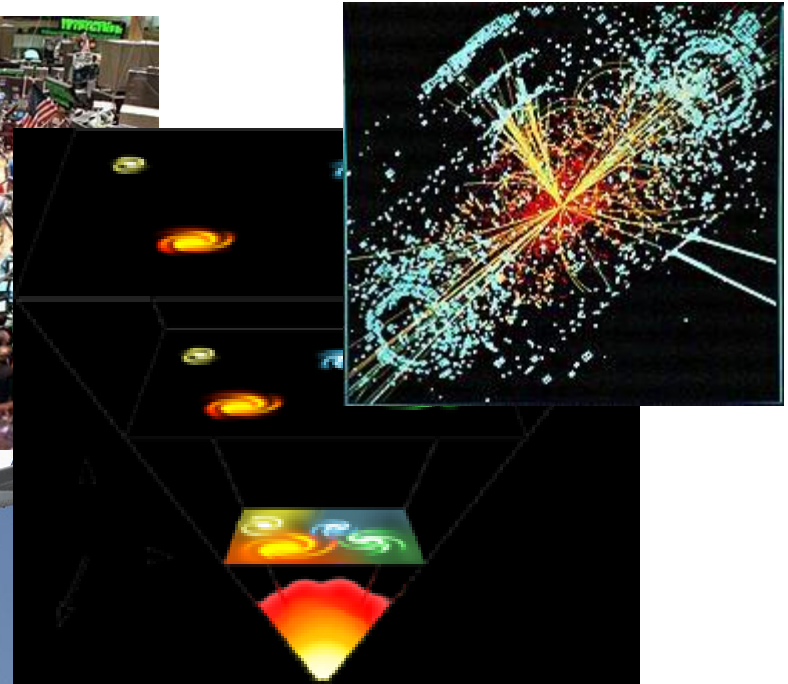
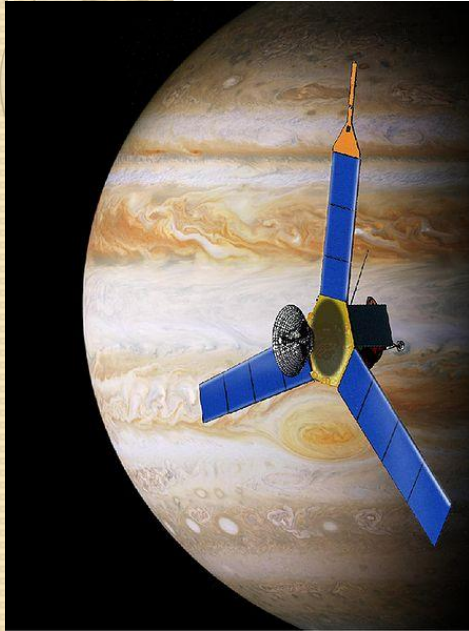

- Why is it difficult to model biological systems?

# Systems Biology

## Wikipedia 2005 version

- “**Systems biology** is an academic field that seeks to integrate high-throughput biological studies to **understand how biological systems function**. By studying the relationships and interactions between various parts of a biological system (e.g. metabolic pathways, organelles, cells, physiological systems, organisms etc.) it is hoped that eventually an understandable model of the whole system can be developed.”
- “**Computational systems biology** is the algorithm and application development arm of systems biology... Computational systems biology aims to develop and use efficient algorithms, data structures and communication tools to orchestrate the integration of large quantities of biological data with the **goal of modeling dynamic characteristics of a biological system**.”

Y Lazebnik. "Can a biologist fix a radio?—Or, what I learned while studying apoptosis" *Cancer Cell*. 2002 Sep;2(3):179-82.

<http://www.ncbi.nlm.nih.gov/pubmed/12242150>

## C O R R E S P O N D E N C E

### Can a biologist fix a radio?—Or, what I learned while studying apoptosis

As a freshly minted Assistant Professor, I feared that everything in my field would be discovered before I even had a chance to set up my laboratory. Indeed, the field of apoptosis, which I had recently joined, was developing at a mind-boggling speed. Components of the previously mysterious process were being discovered almost weekly, frequent scientific meetings had little overlap in their contents, and it seemed that every issue of *Cell*, *Nature*, or *Science* had to have at least one paper on apoptosis. My fear led me to seek advice from David Papermaster (currently at the University of Connecticut), who I knew to be a person with pronounced common sense and extensive experience. David listened to my outpouring of primal fear and explained why I should not worry.

David said that every field he witnessed during his decades in biological research developed quite similarly. At the first stage, a small number of scientists would somewhat leisurely discuss a problem that would appear esoteric to others, such as whether cell cycle is controlled by an oscillator or whether cells can commit suicide. At this stage the understanding of the problem increases slowly, and scientists are generally nice to each other, a few personal antipathies notwithstanding. Then, an unexpected observation, such as the discovery of cyclin or the

It becomes slowly apparent that even if the anticipated gold deposits exist, finding them is not guaranteed. At this stage, the Chinese saying that it is difficult to find a black cat in a dark room, especially if there is no cat, comes to mind too often. If you want to continue meaningful research at this time of widespread desperation, David said, learn how to make good tools and how to keep your mind clear under adverse circumstances. I am grateful to David for his advice, which gave me hope and, eventually, helped me to enjoy my research even after my field did reach the state he predicted.

At some point I began to realize that David's paradox has a meaning that is deeper than a survival advice. Indeed, it was puzzling to me why this paradox manifested itself not only in studies of fundamental processes, such as apoptosis or cell cycle, but even in studies of individual proteins. For example, the mystery of what the tumor suppressor p53 actually does seems only to deepen as the number of publications about this protein rises above 23,000.

The notion that your work will create more confusion is not particularly stimulating, which made me look for guidance again. Joe Gall at the Carnegie Institution, who started to publish before I was born, and is an author of an excellent series of essays on the history of biology (Gall, 1996), relieved my mental suffering by pointing out that a period of stagnation is eventually interrupted by a new development. As an example, he referred to the studies of cell death that took place in the nineteenth century (Gall, 1996, chapter 20), faded into oblivion, and

Y Lazebnik. "Can a biologist fix a radio?--Or, what I learned while studying apoptosis" *Cancer Cell*. 2002 Sep;2(3):179-82.

<http://www.ncbi.nlm.nih.gov/pubmed/12242150>

C O R R E S P O N D E N C E

"My radio has about a hundred various components, such as resistors, capacitors, and transistors, which is comparable to the number of molecules in a reasonably complex signal transduction pathway. I started to contemplate how biologists would determine why my radio does not work and how they would attempt to repair it. Because a majority of biologists pay little attention to physics, I had to assume that all we would know about the radio is that it is a box that is supposed to play music."

My fear led me to seek advice from David Papermaster (currently at the University of Connecticut), who I knew to be a person with pronounced common sense and extensive experience. David listened to my outpouring of primal fear and explained why I should not worry.

David said that every field he witnessed during his decades in biological research developed quite similarly. At the first stage, a small number of scientists would somewhat leisurely discuss a problem that would appear esoteric to others, such as whether cell cycle is controlled by an oscillator or whether cells can commit suicide. At this stage the understanding of the problem increases slowly, and scientists are generally nice to each other, a few personal antipathies notwithstanding. Then, an unexpected observation, such as the discovery of cyclins or the

studies of fundamental processes, such as apoptosis or cell cycle, but even in studies of individual proteins. For example, the mystery of what the tumor suppressor p53 actually does seems only to deepen as the number of publications about this protein rises above 23,000.

The notion that your work will create more confusion is not particularly stimulating, which made me look for guidance again. Joe Gall at the Carnegie Institution, who started to publish before I was born, and is an author of an excellent series of essays on the history of biology (Gall, 1996), relieved my mental suffering by pointing out that a period of stagnation is eventually interrupted by a new development. As an example, he referred to the studies of cell death that took place in the nineteenth century (Gall, 1996, chapter 20), faded into oblivion, and

Y Lazebnik. "Can a biologist fix a radio?--Or, what I learned while studying apoptosis" *Cancer Cell*. 2002 Sep;2(3):179-82.

<http://www.ncbi.nlm.nih.gov/pubmed/12242150>

C O R R E S P O N D E N C E

"How would we begin? First, we would secure funds to obtain a large supply of identical functioning radios in order to dissect and compare them to the one that is broken. We would eventually find how to open the radios and will find objects of various shape, color, and size. We would describe and classify them into families according to their appearance. We would describe a family of square metal objects, a family of round brightly colored objects with two legs, round-shaped objects with three legs and so on."

tenly at the University of Connecticut, who I know to be a person with pronounced common sense and extensive experience. David listened to my outpouring of primal fear and explained why I should not worry.

David said that every field he witnessed during his decades in biological research developed quite similarly. At the first stage, a small number of scientists would somewhat leisurely discuss a problem that would appear esoteric to others, such as whether cell cycle is controlled by an oscillator or whether cells can commit suicide. At this stage the understanding of the problem increases slowly, and scientists are generally nice to each other, a few personal antipathies notwithstanding. Then, an unexpected observation, such as the discovery of cyclin or the

cycle, but even in studies of individual proteins. For example, the mystery of what the tumor suppressor p53 actually does seems only to deepen as the number of publications about this protein rises above 23,000.

The notion that your work will create more confusion is not particularly stimulating, which made me look for guidance again. Joe Gall at the Carnegie Institution, who started to publish before I was born, and is an author of an excellent series of essays on the history of biology (Gall, 1996), relieved my mental suffering by pointing out that a period of stagnation is eventually interrupted by a new development. As an example, he referred to the studies of cell death that took place in the nineteenth century (Cell, 1999, chapter 20), faded into oblivion, and

Y Lazebnik. "Can a biologist fix a radio?--Or, what I learned while studying apoptosis" *Cancer Cell*. 2002 Sep;2(3):179-82.

<http://www.ncbi.nlm.nih.gov/pubmed/12242150>

C O R R E S P O N D E N C E

"A more successful approach will be to remove components one at a time or to use a variation of the method, in which a radio is shot at a close range with metal particles. In the latter case radios that malfunction (have a "phenotype") are selected to identify the component whose damage causes the phenotype. Although removing some components will have only an attenuating effect, a lucky postdoc will accidentally find a wire whose deficiency will stop the music completely."

David listened to my outpouring of primal fear and explained why I should not worry.

David said that every field he witnessed during his decades in biological research developed quite similarly. At the first stage, a small number of scientists would somewhat leisurely discuss a problem that would appear esoteric to others, such as whether cell cycle is controlled by an oscillator or whether cells can commit suicide. At this stage the understanding of the problem increases slowly, and scientists are generally nice to each other, a few personal antipathies notwithstanding. Then, an unexpected observation, such as the discovery of cyclin or the

mystery of what the tumor suppressor p53 actually does seems only to deepen as the number of publications about this protein rises above 23,000.

The notion that your work will create more confusion is not particularly stimulating, which made me look for guidance again. Joe Gall at the Carnegie Institution, who started to publish before I was born, and is an author of an excellent series of essays on the history of biology (Gall, 1996), relieved my mental suffering by pointing out that a period of stagnation is eventually interrupted by a new development. As an example, he referred to the studies of cell death that took place in the nineteenth century (Gall, 1996, chapter 20), faded into oblivion, and

Y Lazebnik. "Can a biologist fix a radio?--Or, what I learned while studying apoptosis" *Cancer Cell*. 2002 Sep;2(3):179-82.

<http://www.ncbi.nlm.nih.gov/pubmed/12242150>

C O R R E S P O N D E N C E

"A more successful approach will be to remove components one at a time or to use a variation of the method, in which a radio is shot at a close range with metal particles. In the latter case radios that malfunction (have a "phenotype") are selected to identify the component whose damage causes the phenotype. Although removing some components will have only an attenuating effect, a lucky postdoc will accidentally find a wire whose deficiency will stop the music completely."

"What is the probability that this radio will be fixed by our biologists? I might be overly pessimistic, but a textbook example of the monkey that can, in principle, type a Burns poem comes to mind. In other words, the radio will not play music unless that lucky chance meets a prepared mind.

Yet, we know with near certainty that an engineer, or even a trained repairman could fix the radio. What makes the difference?"

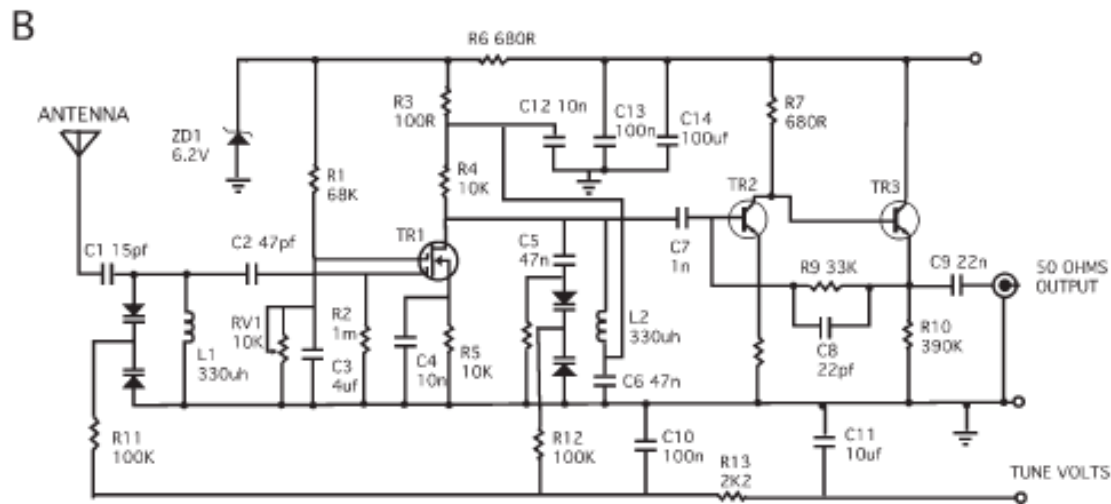
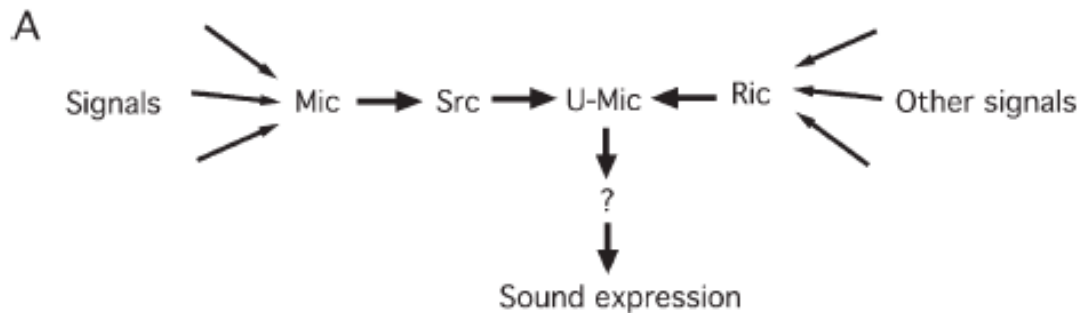

**Figure 3.** The tools used by biologists and engineers to describe processes of interest

**A:** The biologist's view of a radio. See Figure 2 and text for description of the indicated components. **B:** The engineer's view of a radio. (Please note that the circuit diagram presented is not that of the radio used in the study. The diagram of the radio was lost, which, in part, explains why the radio remains broken.)

“Because the language is standard (the elements and their connections are described according to invariable rules), any engineer trained in electronics would unambiguously understand a diagram describing the radio or any other electronic device. As a consequence, engineers can discuss the radio using terms that are understood unambiguously by the parties involved. Moreover, the commonality of the language allows engineers to identify familiar patterns or modules (a trigger, an amplifier, etc.) in a diagram of an unfamiliar device..”

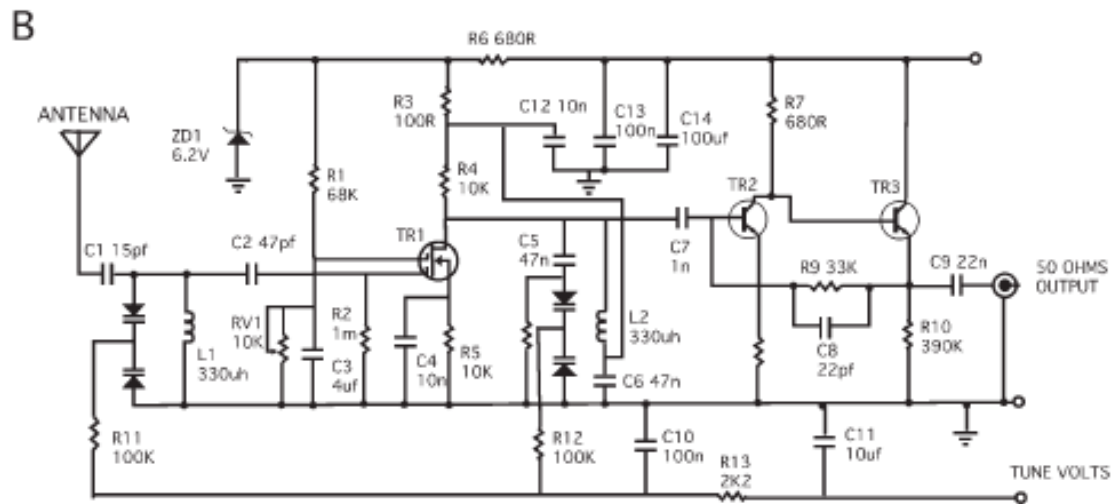
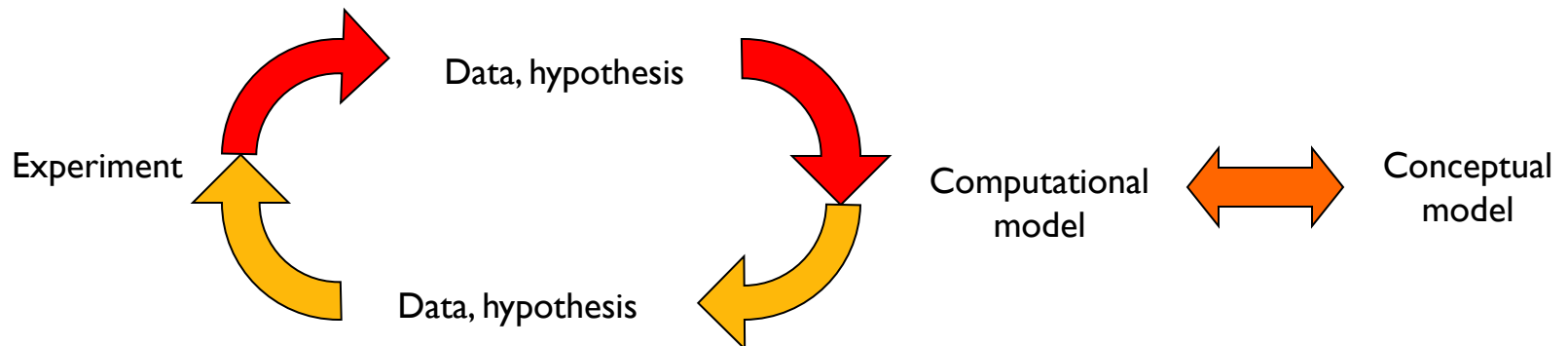

**Figure 3.** The tools used by biologists and engineers to describe processes of interest

**A:** The biologist's view of a radio. See Figure 2 and text for description of the indicated components. **B:** The engineer's view of a radio. (Please note that the circuit diagram presented is not that of the radio used in the study. The diagram of the radio was lost, which, in part, explains why the radio remains broken.)

# Some quotes about models

- ❖ **“All models are wrong, but some are useful”** (George Box). All models involve assumptions and simplifications, and you should interpret the predictions and results accordingly.
- ❖ **“Entities should not be multiplied unnecessarily”** (William of Occam). A modern version of Occam's Razor is: If you have two theories that both explain the observed facts then you should use the simplest one until more evidence comes along - also called the Law of Parsimony.
- ❖ **“Mathematics has no symbols for confused ideas”** (George Stigler). Think before you compute.
- ❖ **“Make your theory as simple as possible, but no simpler.”** (Albert Einstein).
- ❖ **“For every complex question there is a simple and wrong solution.”** (Albert Einstein)



# What is modelling ?

Potential energy =  $m g h$

$m$  = mass of apple

$g$  = acceleration due to gravity

$h$  = height of apple above ground

Kinetic energy =  $\frac{1}{2} m v^2$

$v$  = velocity

When the apple hits the ground  
potential energy = kinetic energy

So,

$$\frac{1}{2} m v^2 = m g h, \quad \frac{1}{2} v^2 = g h$$

We also know that  $v = g t$ , so

$$\frac{1}{2} g^2 t^2 = g h, \text{ so}$$

$$h = \frac{1}{2} g t^2, \text{ and } t = \sqrt{2h/g}$$

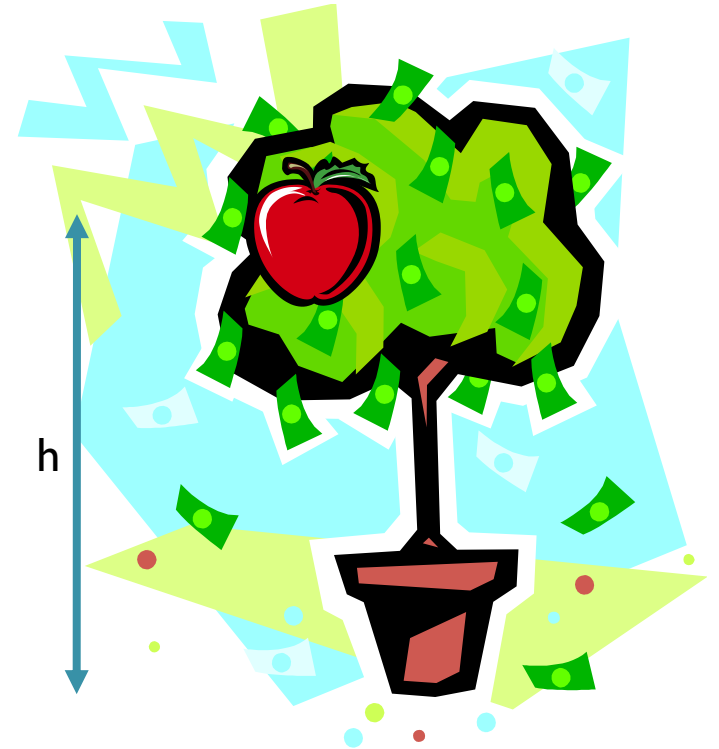

# What is modelling ?

We can use this simple model to predict the depth of a flooded mineshaft – or well



$$h = \frac{1}{2} g t^2, \text{ and } t = \sqrt{2h/g},$$

$$\text{So if } t = 5 \text{ s, } h = \frac{1}{2} \times 9.81 \times 5^2 = 122 \text{ m}$$

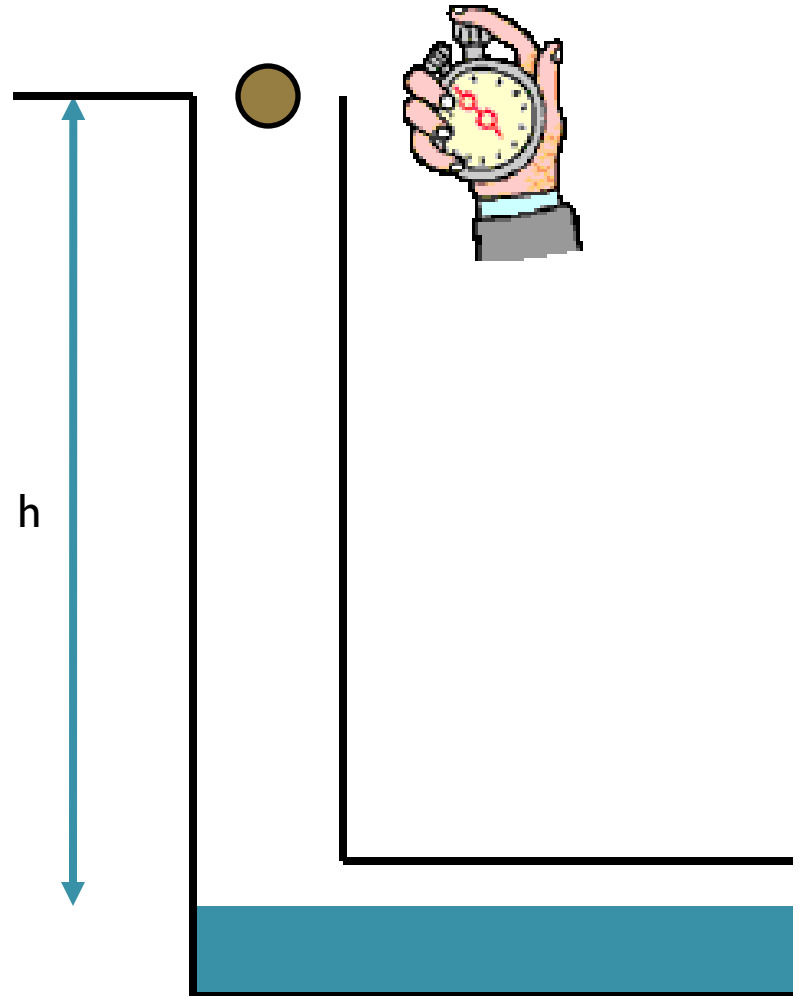

# What is modelling ?

We can use this simple model to predict the depth of a flooded mineshaft – or well

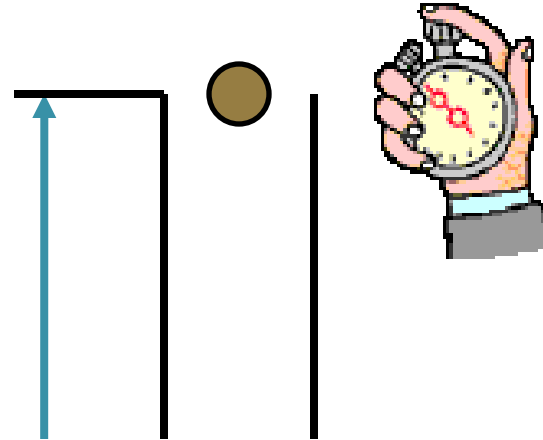

$$h = \frac{1}{2} g t^2, \text{ and } t = \sqrt{2h/g},$$

$$\text{So if } t = 5 \text{ s, } h = \frac{1}{2} \times 9.81 \times 5^2 = 122 \text{ m}$$

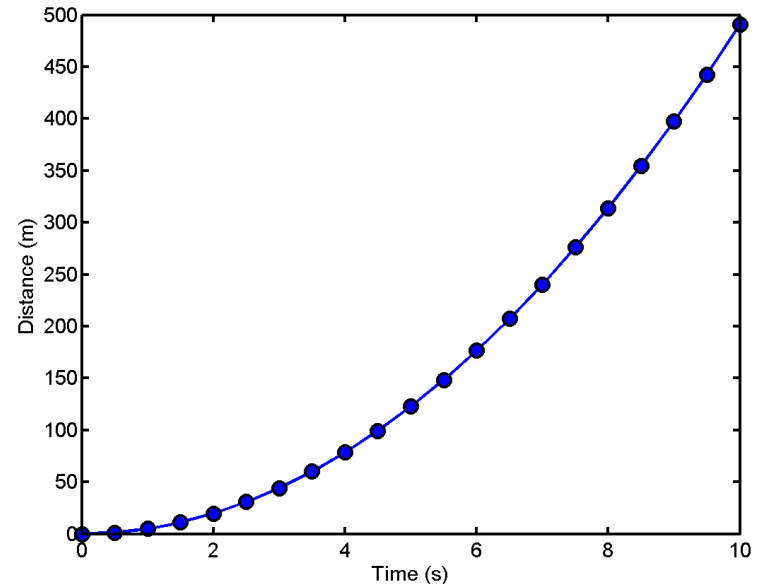

# This approach *is* rocket science

How fast does a rocket need to go to escape Earth's gravity?

Kinetic energy  $\geq$  potential energy

$$\frac{1}{2} m v^2 \geq m g h, \quad \text{so} \quad \frac{1}{2} v^2 \geq g h$$

Assuming we can treat the Earth as a point mass, then  $h$  is the radius of the Earth, which is about 6300 km

The **escape velocity** is then

$$v \geq \sqrt{(2 g h)} = \sqrt{(2 \times 9.81 \times 6300000)}$$

$$v \geq 11117 \text{ ms}^{-1} \text{ (about 10x speed of a rifle bullet)}$$

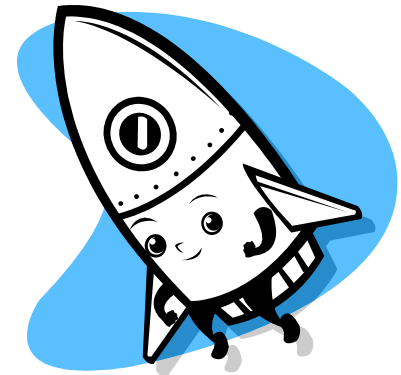

# Summary so far

- Models of natural systems are based on physical laws – for example Newton's second law,  $\text{force} = \text{mass} \times \text{acceleration}$
- These models may be constrained by initial conditions – we could have given our apple an initial velocity
- Sometimes we need to make assumptions – for example we assumed the Earth can be treated as a point mass

# Simple example – predator and prey

Simple description of processes:

- Rabbits breed, so the number of rabbits increases at a rate proportional to the current population.
- When foxes are present, the rabbit population decreases at a rate proportional to the number of foxes and the number of rabbits.
- Foxes die from old age, and so the population decreases at a rate proportional to the number of foxes.
- Foxes breed when there are prey to eat, so the fox population increases at a rate proportional to the number of rabbits and the number of foxes.

# Simple example – predator and prey

- Within our system, rabbits and foxes are conserved
- For each species, the change in population in a time interval is determined by the number of births (+) and the number of deaths (-)
- For rabbits,  
$$\text{population change} = \text{births} - \text{deaths due to predation}$$
- This is a conservation equation, which constrains the system
- In natural systems matter, momentum, and energy are all usually conserved, and these ideas can be used to constrain our models.

# Simple example – predator and prey

We can write these processes down as chemical reactions:

- Rabbits breed, so the number of rabbits increases at a rate proportional to the current population.
  - $\text{prey} \rightarrow 2 * \text{prey}$
- When foxes are present, the rabbit population decreases at a rate proportional to the number of foxes and the number of rabbits.
  - $\text{predator} + \text{prey} \rightarrow \text{predator}$
- Foxes die from old age, and so the population decreases at a rate proportional to the number of foxes.
  - $\text{predator} \rightarrow 0$
- Foxes breed when there are prey to eat, so the fox population increases at a rate proportional to the number of rabbits and the number of foxes.
  - $\text{predator} + \text{prey} \rightarrow 2 * \text{predator} + \text{prey}$

# Simple example – predator and prey

We can write these processes down as equations:

- Rabbits breed, so the number of rabbits increases at a rate proportional to the current population.
  - $\text{prey} \rightarrow 2 * \text{prey}$ ,  $\text{change in prey} = A * \text{prey}$
- When foxes are present, the rabbit population decreases at a rate proportional to the number of foxes and the number of rabbits.
  - $\text{predator} + \text{prey} \rightarrow \text{predator}$ ,  $\text{change in prey} = -B * \text{prey} * \text{predator}$
- Foxes die from old age, and so the population decreases at a rate proportional to the number of foxes.
  - $\text{predator} \rightarrow 0$ ,  $\text{change in predator} = -C * \text{predator}$
- Foxes breed when there are prey to eat, so the fox population increases at a rate proportional to the number of rabbits and the number of foxes.
  - $\text{predator} + \text{prey} \rightarrow 2 * \text{predator} + \text{prey}$ ,  
 $\text{change in predator} = D * \text{predator} * \text{prey}$

# Simple example – predator and prey

- Total change in prey population in a short time  $dt$  is given by births minus deaths:
- $d\text{Prey} = A * \text{prey} * dt - B * \text{prey} * \text{predator} * dt$   
(note that if there are no predators, the population will continue to increase)
- Total change in predator population in a short time  $dt$  is also given by births minus deaths:
- $d\text{Pred} = D * \text{predator} * \text{prey} * dt - C * \text{predator} * dt$   
(note that if there are no prey, the population will decrease to 0)
- These can be expressed as **differential equations**, where  $x$  represents the prey population and  $y$  the predator population:

$$\frac{dx}{dt} = Ax(t) - Bx(t)y(t),$$

$$\frac{dy}{dt} = Dx(t)y(t) - Cy(t)$$

# Simple example – predator and prey

$$\frac{dx}{dt} = Ax(t) - Bx(t)y(t), \quad \frac{dy}{dt} = Dx(t)y(t) - Cy(t)$$

- These equations can immediately tell us something about the system.
- If  $dx/dt = 0$  and  $dy/dt = 0$ , then the system is in equilibrium, i.e. the numbers of predator and prey are exactly balanced.
- This occurs when

$$0 = Ax(t) - Bx(t)y(t), \quad 0 = Dx(t)y(t) - Cy(t)$$

- And there are solutions for  $x=0$  and  $y = 0$ , and for  $x = C/D$  and  $y = A/B$

# Simple example – predator and prey

- This tells us about a steady-state solution, but how does the system behave in time?
- For this we need to have **initial values** of  $x$  and  $y$  (prey and predator), as well as values of the rate constants  $A$ ,  $B$ ,  $C$ , and  $D$ .
- From this information we can calculate a **numerical solution** of the system of equations.
- One way we can do this is to approximate  $dx/dt$  over a short time step  $\Delta t$

$$\frac{dx}{dt} = Ax(t) - Bx(t)y(t) \cong \frac{x^{t+\Delta t} - x^t}{\Delta t} = Ax^t - Bx^t y^t$$

$$x^{t+\Delta t} = x^t + \Delta t(Ax^t - Bx^t y^t)$$

$$y^{t+\Delta t} = y^t + \Delta t(Dx^t y^t - Cy^t)$$

# Simple example – predator and prey

- This approach gives us estimates of  $x$  and  $y$  at discrete times  $t, t+\Delta t, t+2\Delta t, \dots$
- For  $A = 1, B = 0.01, C = 1, D = 0.02$ , initial values of  $x$  and  $y$  of 20, and  $\Delta t = 0.001$ , we get an oscillation in predator and prey

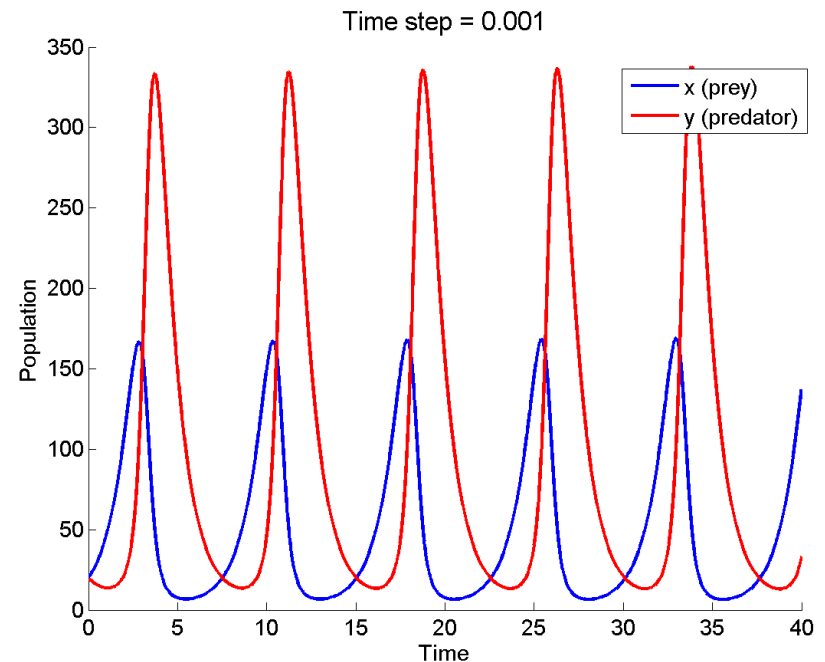

# Simple example – predator and prey

- This approach gives us estimates of  $x$  and  $y$  at discrete times  $t, t+\Delta t, t+2\Delta t, \dots$
- For  $A = 1, B = 0.01, C = 1, D = 0.02$ , initial values of  $x$  and  $y$  of 20, and  $\Delta t = 0.001$ , we get an oscillation in predator and prey
- Increasing  $\Delta t$  to 0.05, we get different behaviour, with an increase in amplitude

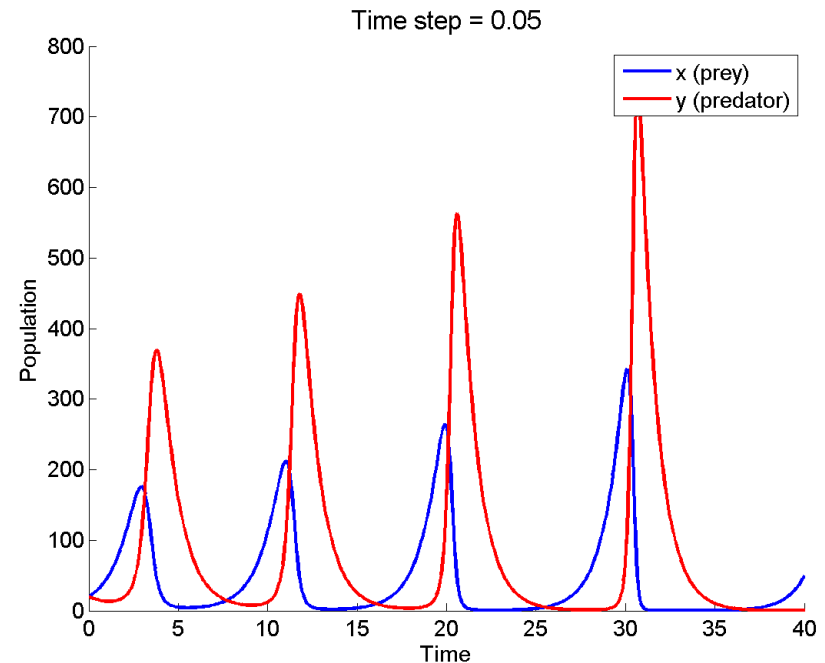

# Simple example – predator and prey

- This approach gives us estimates of  $x$  and  $y$  at discrete times  $t, t+\Delta t, t+2\Delta t, \dots$
- For  $A = 1, B = 0.01, C = 1, D = 0.02$ , initial values of  $x$  and  $y$  of 20, and  $\Delta t = 0.001$ , we get an oscillation in predator and prey
- Increasing  $\Delta t$  further to 0.125, we get a major problem, with negative populations!
- Increasing  $\Delta t$  beyond 0.125 results in major numerical instability.

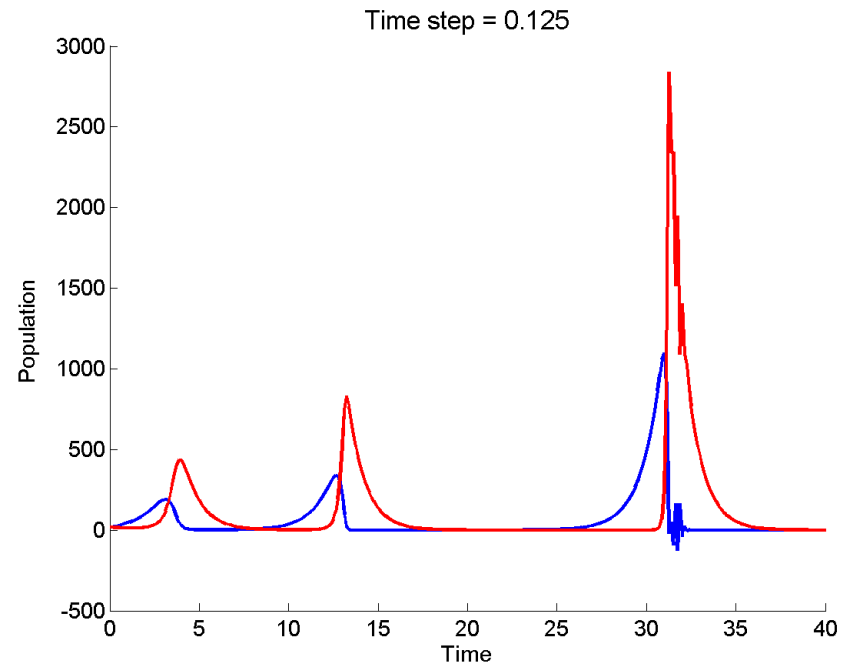

# Problems with the Euler method

What has gone wrong?

$$\frac{dx}{dt} = f(x) \approx \frac{x_t - x_{t-1}}{dt} = f(x) , \text{ so } x_t \approx x_{t-1} + dt \cdot f(x)$$

The Euler approximation has some serious limitations because it uses the gradient at the current point  $x_t$  to predict the value of the next point  $x_{t+1}$ .

If the time step  $dt$  is small compared with changes in gradient the method works quite well.

If not then it is prone to serious errors.

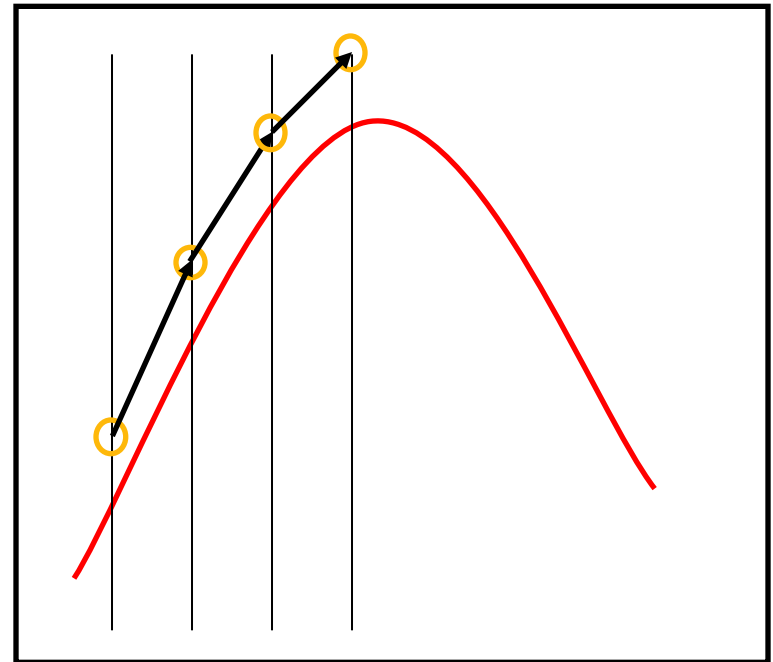

# Problems with the Euler method

What has gone wrong?

$$\frac{dx}{dt} = f(x) \approx \frac{x_t - x_{t-1}}{dt} = f(x) , \text{ so } x_t \approx x_{t-1} + dt \cdot f(x)$$

The Euler approximation has some serious limitations because it uses the gradient at the current point  $x_t$  to predict the value of the next point  $x_{t+1}$ .

If the time step  $dt$  is small compared with changes in gradient the method works quite well.

If not then it is prone to serious errors.

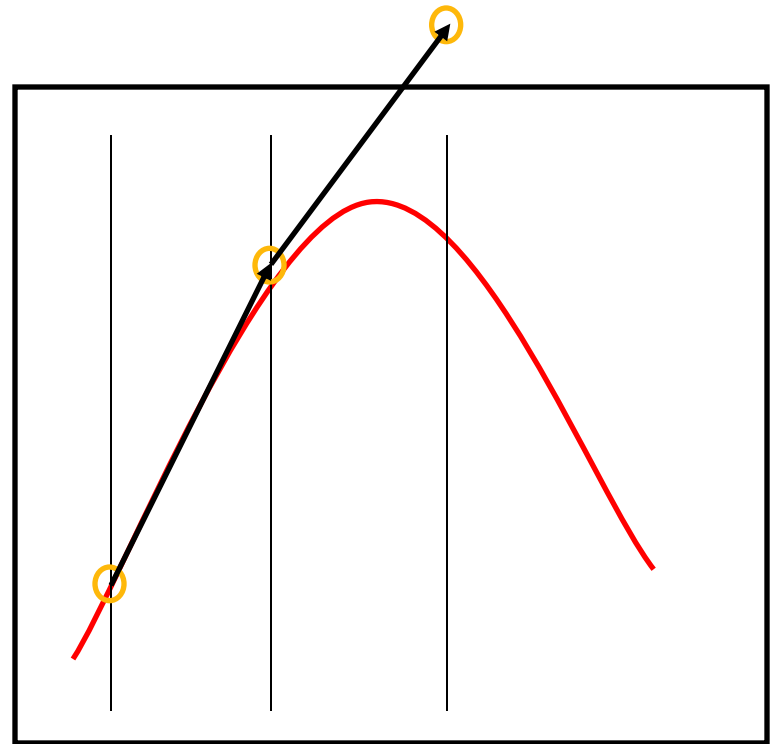

# Alternative numerical methods

A vast subject.

A modified Euler method finds a point midway across the interval.

Euler method.

Modified Euler method (midpoint).

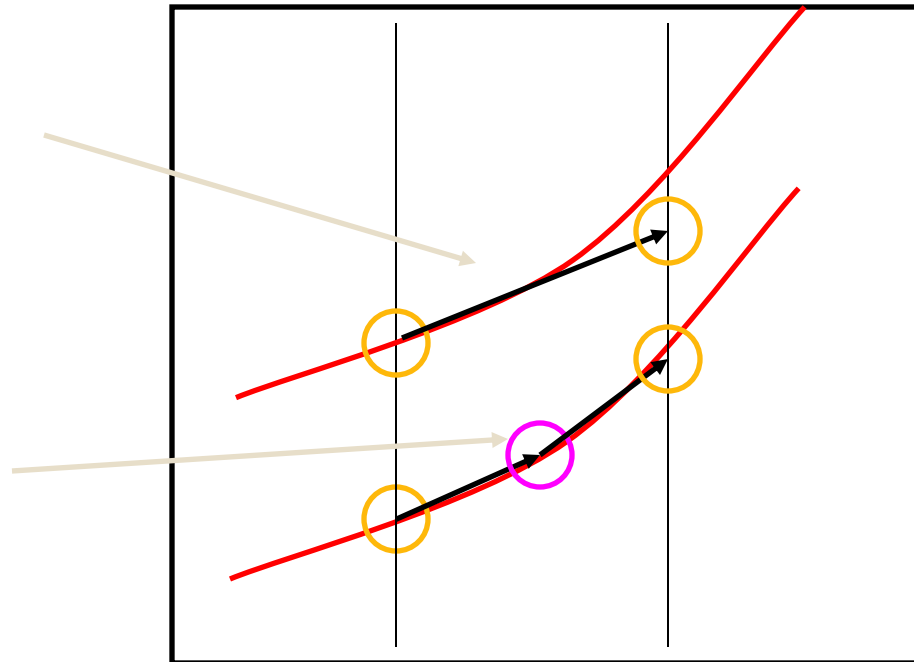

There are a host of other numerical approaches for solving differential equations – each have advantages and disadvantages.

# Good news

- There are many software applications that will solve these kind of equations for you.
- These applications will often choose an appropriate numerical solver,
- **But**, you need to be aware that sometime numerical errors can occur

# Copasi – Complex Pathway Simulator

- COPASI is a simulator for biochemical networks.
- It is a tool for solving systems of equations representing chemical reactions.
- It is freely available, and implements stable and fast numerical techniques.

# Predator prey model in Copasi

- Thanks to Ion PETRE and Andrzej MIZERA Turku, Finland)
- File → New
- Model
  - time units: *hours*
  - volume unit:  $m^3$
  - quantity unit: *#*
- Biochemical → Compartments: *forest*
- Biochemical → Species: *predator, prey*
  - *Initial concentrations 20*
- Biochemical → Reactions:
  - growth of prey population (A): *prey -> 2 prey*
  - consumption of prey (B): *predator + prey -> predator*
  - death of predators (C): *predator ->*
  - increase of predator population (due to prey consumption) (D):  
*predator + prey -> 2 predator + prey*

# Predator prey model in Copasi

- Biochemical → Reactions A, B, C, D
- Enter parameters
  - $A = 1$ ;
  - $B = 0.01$ ;
  - $C = 1$ ;
  - $D = 0.02$ ;
- Tasks → Time Course
  - Duration 40
  - Interval size 0.1
- Hit the Run button

# Predator prey model in Copasi

Particle Numbers, Volumes, and Global Quantity Values\_1

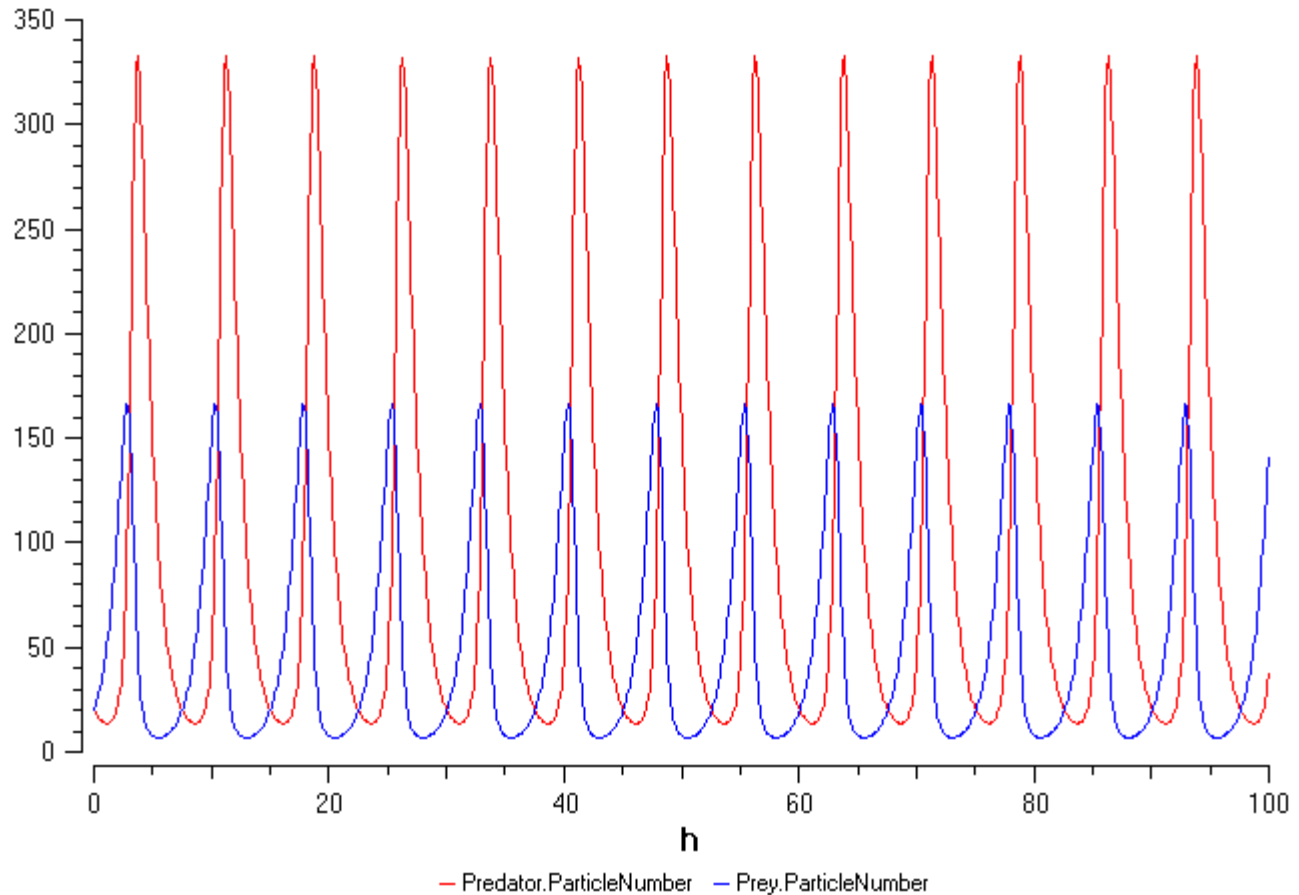

# Predator prey model in Copasi

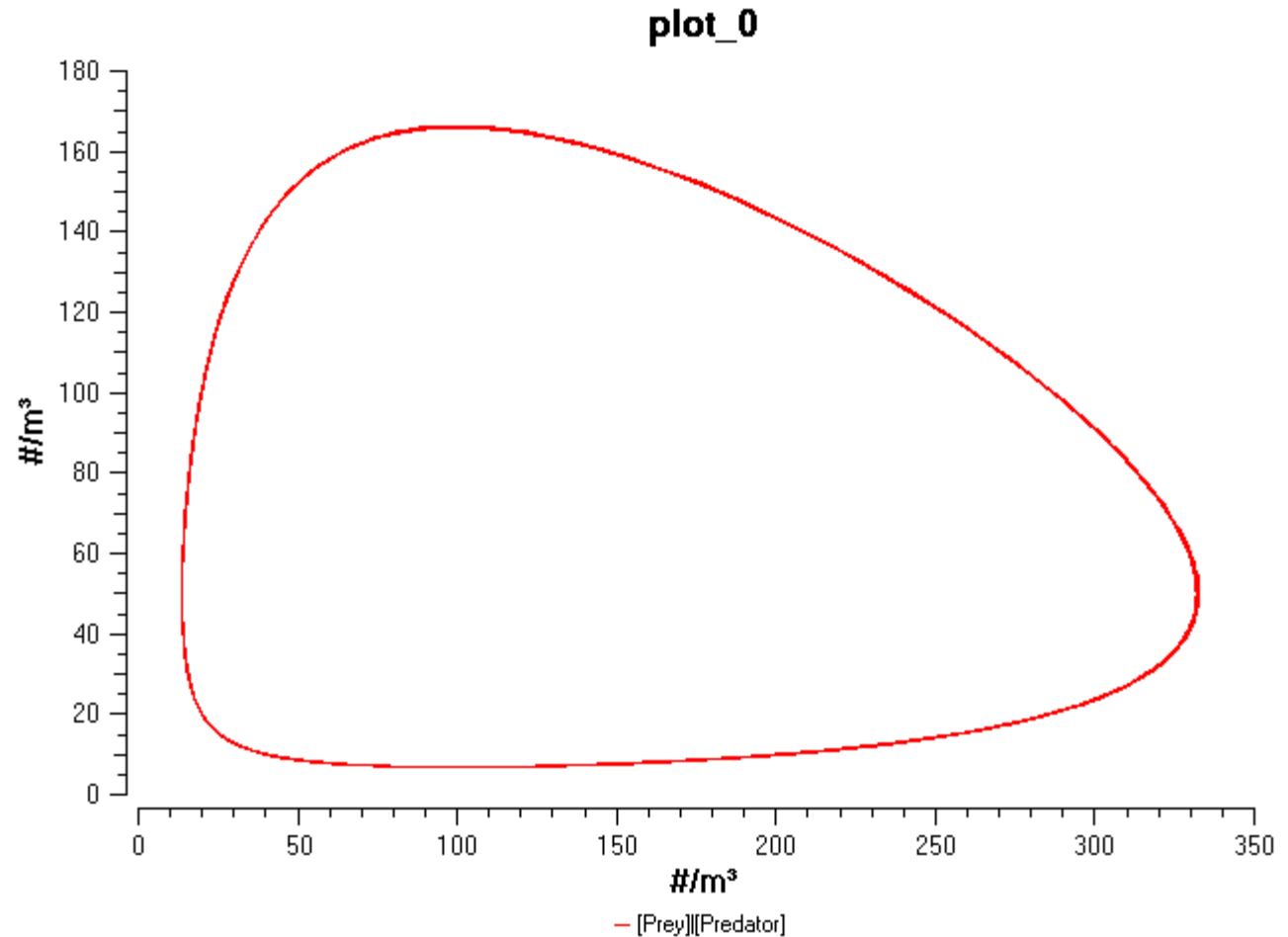

# Predator prey model in Copasi

- The default numerical method is deterministic, and assumes that reagents for chemical reactions are well mixed
- This is not always true in biology, especially when concentrations are very low
- In Time Course → Method select Hybrid (Runge-Kutta)
- This will solve the model equations assuming the reagents (rabbits and foxes) are well mixed if the numbers are high, but using a stochastic (random) method when numbers are low.

# Predator prey model in Copasi

- The outcome is now rather more uncertain

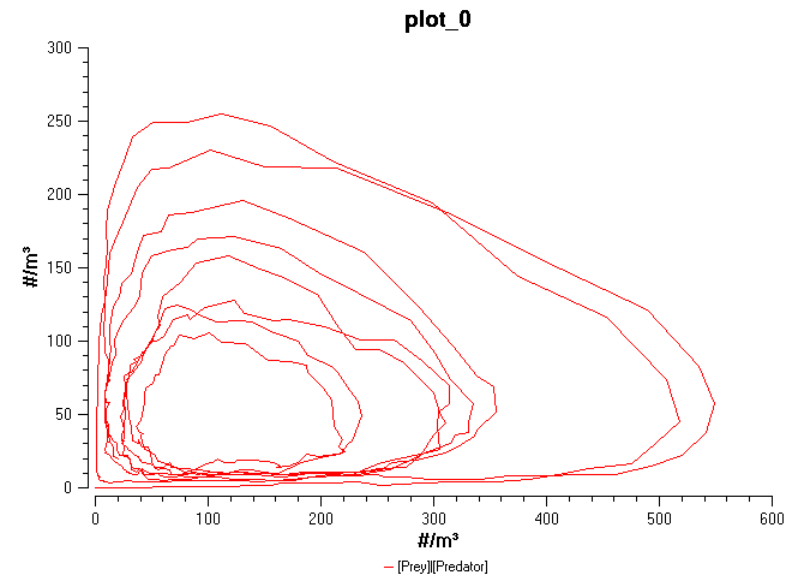
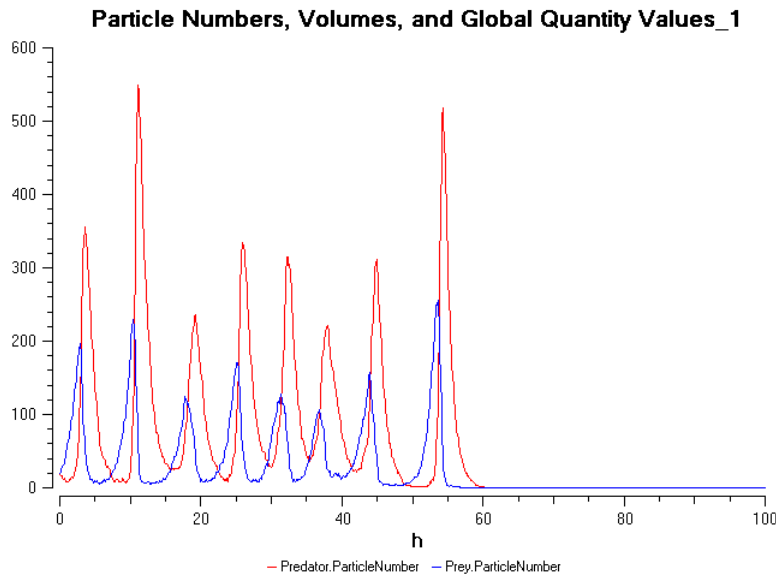

# Summary

- Models are widely used in physical science and engineering to
  - Organise knowledge
  - Make predictions
- Often these models are expressed as differential equations
- Systems of equations can be solved, so that the time course of a particular natural system can be examined.